

Register Transfer Methodology I

Outline

1. Introduction
2. Overview of FSMD
3. FSMD design of a repetitive-addition multiplier
4. Alternative design of a repetitive-addition multiplier
5. Timing and performance analysis of FSMD
6. Sequential add-and-shift multiplier

1. Introduction

- How to realize an algorithm in hardware?
- Two characteristics of an algorithm:
 - Use of variables (symbolic memory location)
e.g., $n = n + 1$ in C
 - Sequential execution
(execution order is important)

- E.g., an algorithm:
 - Summate 4 number
 - Divide the result by 8
 - Round the result
- Pseudocode

```
size = 4
sum = 0;
for i in (0 to size-1) do {
    sum = sum + a(i);}
q = sum / 8;
r = sum rem 8;
if (r > 3) {
    q = q+1;}
outp = q;
```

- “Dataflow” implementation in VHDL
 - Convert the algorithm in to combinational circuit
 - No memory elements
 - The sequence is embedded into the “flow of data”

- VHDL code

```
sum  <= 0;  
sum0 <= a(0);  
sum1 <= sum0 + a(1);  
sum2 <= sum1 + a(2);  
sum3 <= sum2 + a(3);  
q  <= "000" & sum3(8 downto 3);  
r  <= "00000" & sum3(2 downto 0);  
outp <= q + 1 when (r > 3) else  
      q;
```

- Block diagram

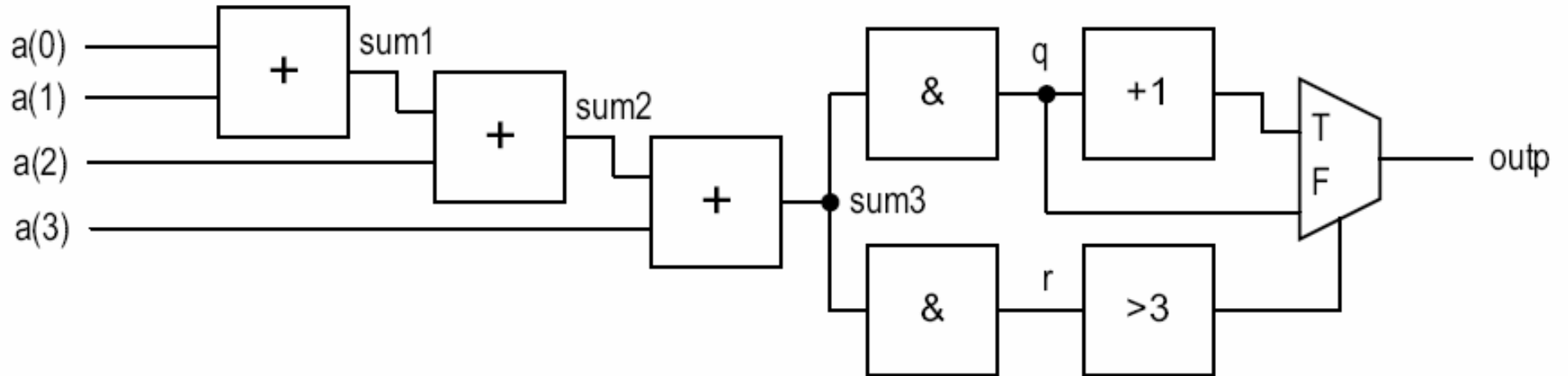

- Problems with dataflow implementation:
 - Can only be applied to trivial algorithm
 - Not flexible
 - Can we just share one adder in a time-multiplexing fashion to save hardware resources
 - What happen if input size is not fixed (i.e., size is determined by an external input)

Register Transfer Methodology

- Realized algorithm in hardware
- Use register to store intermediate data and imitate variable
- Use a datapath to realize all register operations
- Use a control path (FSM) to specify the order of register operation

- The system is specified as sequence of data manipulation/transfer among registers
- Realized by FSM with a datapath (FSMD)

2. Overview of FSMD

Basic RT operation

- Basic form:

$$r_{\text{dest}} \leftarrow f(r_{\text{src1}}, r_{\text{src2}}, \dots, r_{\text{srcn}})$$

- Interpretation:

- At the rising edge of the clock, the output of registers r_{src1} r_{src2} . etc are available
- The output are passed to a combinational circuit that performs $f()$
- At the next rising edge of the clock, the result is stored into r_{dest}

- E.g.,
 $r \leftarrow l$
 $r \leftarrow r$
 $r0 \leftarrow r1$
 $n \leftarrow n - 1$
 $y \leftarrow a \oplus b \oplus c \oplus d$
 $s \leftarrow a^2 + b^2$

- Implementation example

$$r1 \leftarrow r1+r2$$

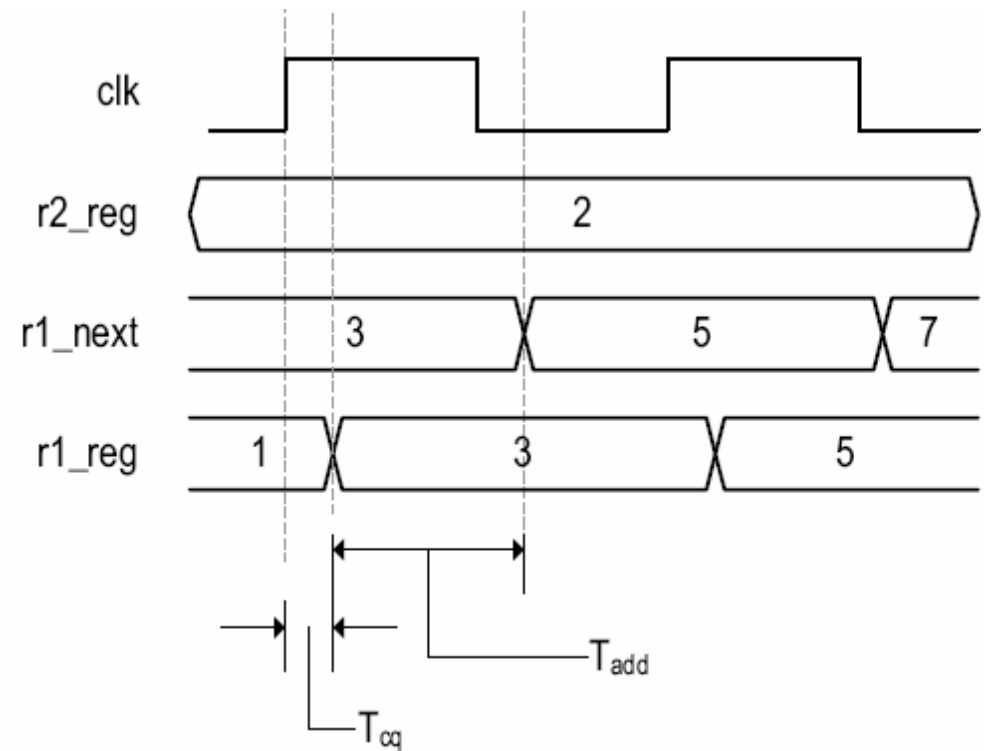
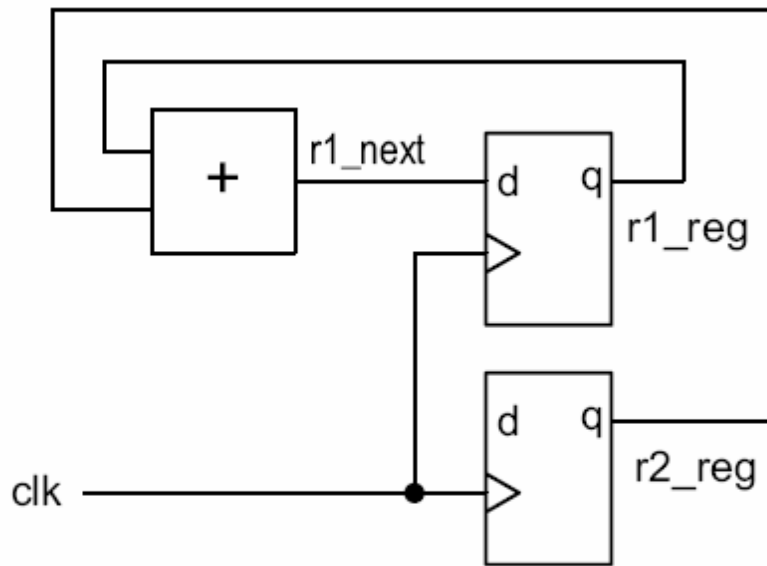

- Multiple RT operations

```
r1 ← 1;  
r1 ← r1 + r2;  
r1 ← r1 + 1;  
r1 ← r1;
```

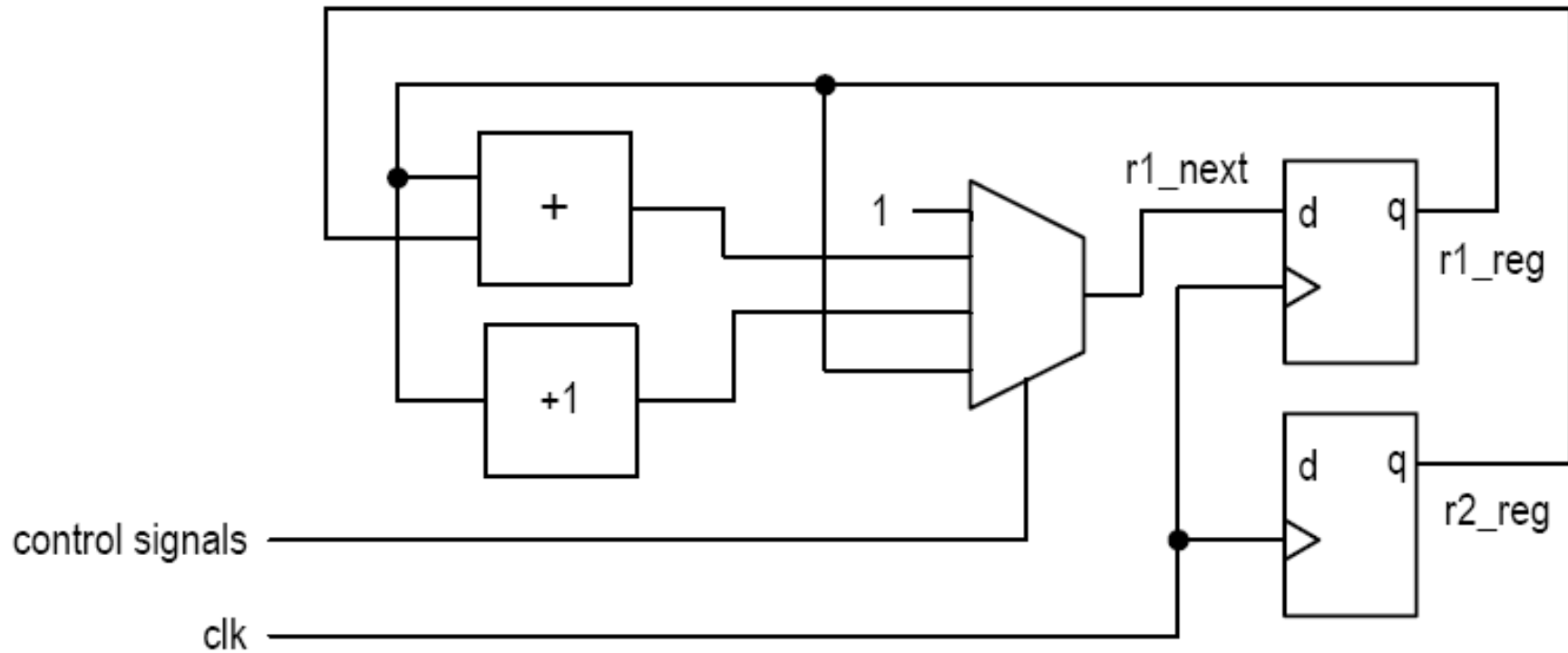

FSM as control path

- FSM is a good to control RT operation
 - State transition is on clock-by-clock basis
 - FSM can enforce order of execution
 - FSM allows branches on execution sequence
- Normally represented in an extended ASM chart known as ASMD (ASM with datapath) chart

- E.g.

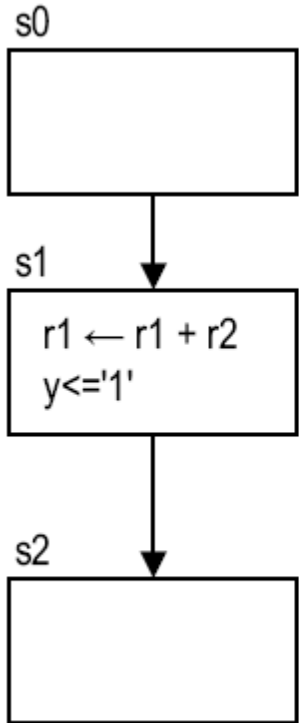

(a)

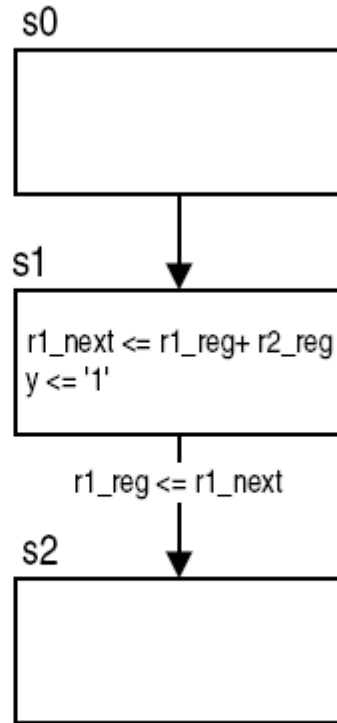

(b)

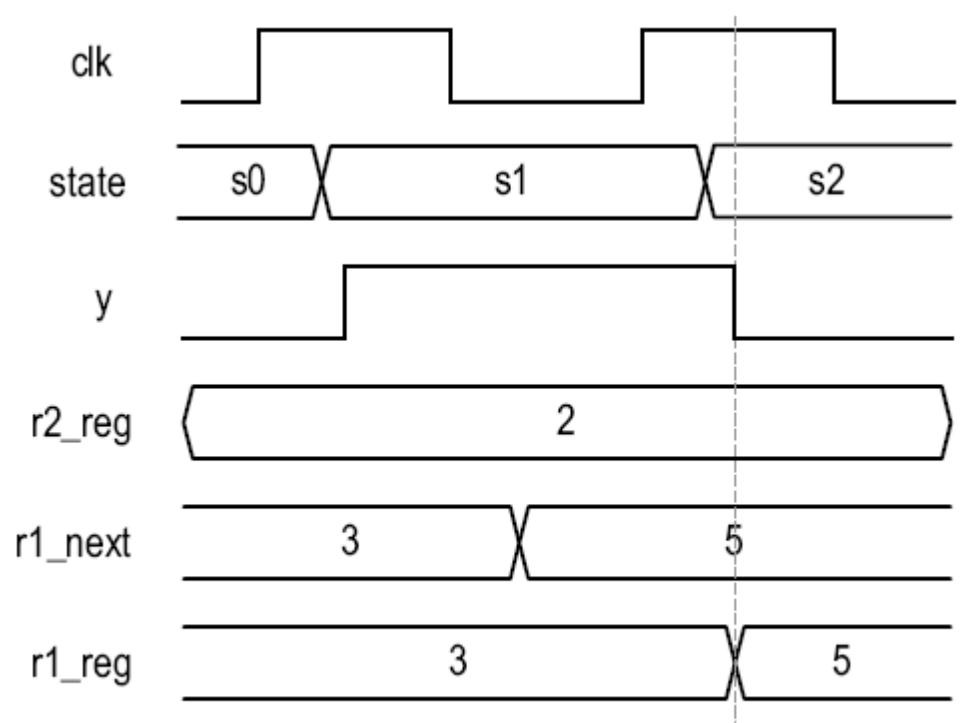

(c) Timing diagram

- Note: new value of r1 is only available when the FSM exits s1 state

Basic Block Diagram of FSMD

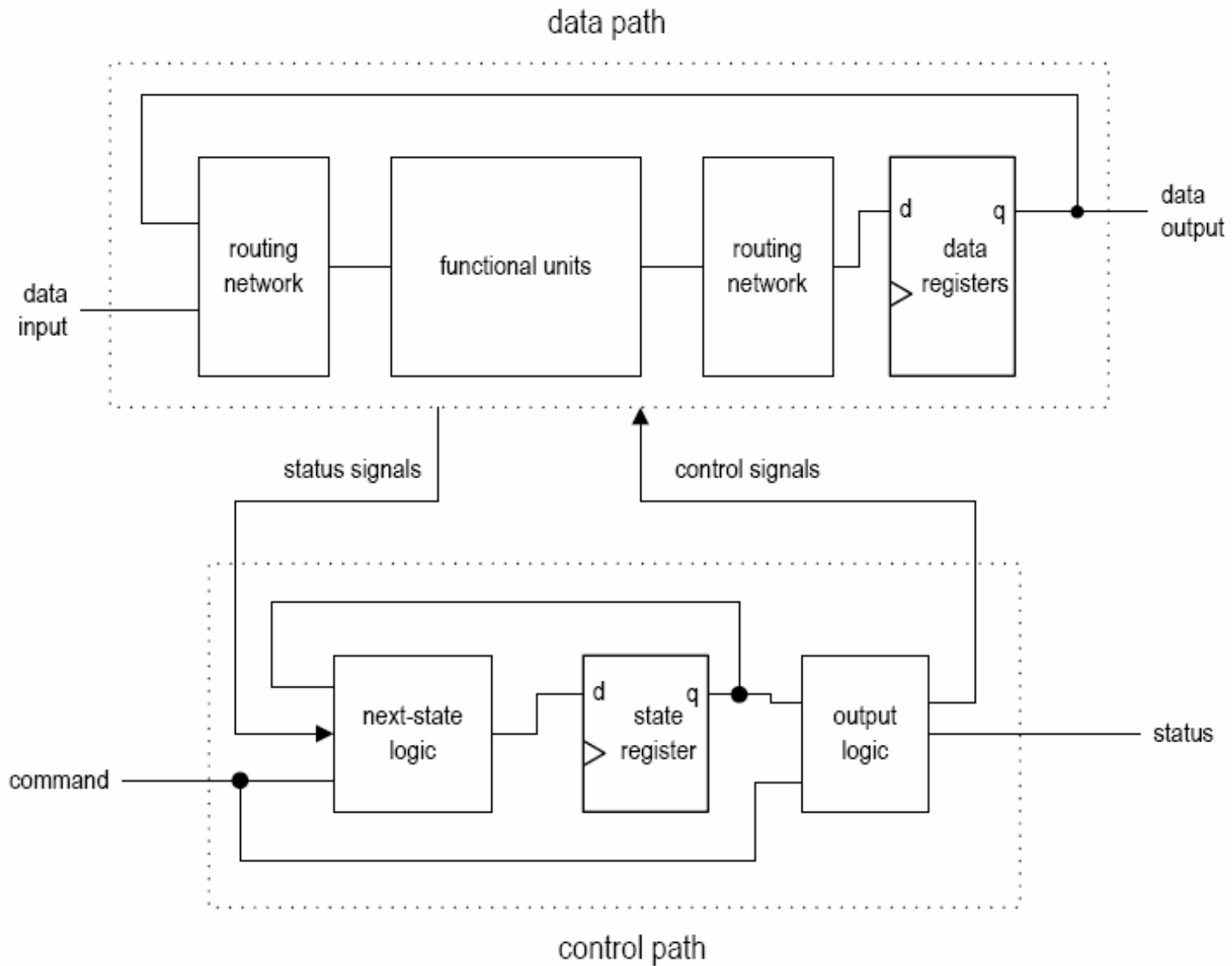

3. FSM design example: Repetitive addition multiplier

- Basic algorithm: $7*5 = 7+7+7+7+7$
- Pseudo code

```
if (a_in=0 or b_in=0) then {  
    r = 0;}  
else{  
    a = a_in;  
    n = b_in;  
    r = 0;  
    while (n != 0 ){  
        r = r + a;  
        n = n-1;}  
}  
return (r)
```

- ASMD-friendly code

```
        if (a_in=0 or b_in=0) then {
            r = 0;}
        else {
            a = a_in;
            n = b_in;
            r = 0;
op:      r = r + a;
            n = n-1;
            if (n = 0) then{
                goto stop;}
            else{
                goto op;}
        }
stop:   return(r);
```

- **Input:**
 - a_in, b_in: 8-bit unsigned
 - clk, reset
 - start: command
- **Output:**
 - r: 16-bit unsigned
 - ready: status
- **ASMD chart**
 - Default RT operation: keep the previous value
 - Note the parallel execution in op state

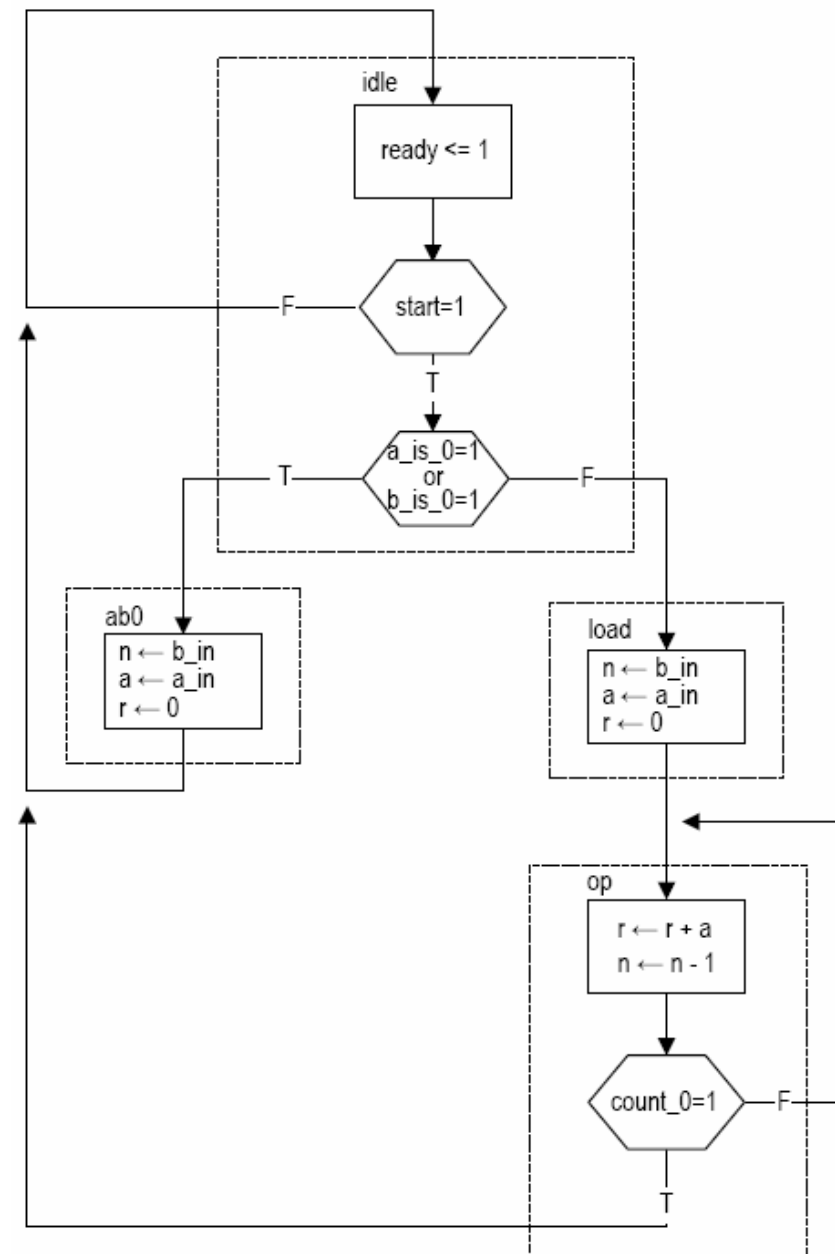

- Construction of the data path
 - List all RT operations
 - Group RT operation according to the destination register
 - Add combinational circuit/mux
 - Add status circuits
- E.g
 - RT operations with the r register:
 - $r \leftarrow r$ (in the idle state)
 - $r \leftarrow 0$ (in the load and op states)
 - $r \leftarrow r + b$ (in the op state)
 - RT operations with the n register:
 - $n \leftarrow n$ (in the idle state)
 - $n \leftarrow a_in$ (in the load and ab0 states)
 - $n \leftarrow n - 1$ (in the op state)
 - RT operations with the b register:
 - $b \leftarrow b$ (in the idle and op states)
 - $b \leftarrow b_in$ (in the load and ab0 states)

- E.g., Circuit associated with r register

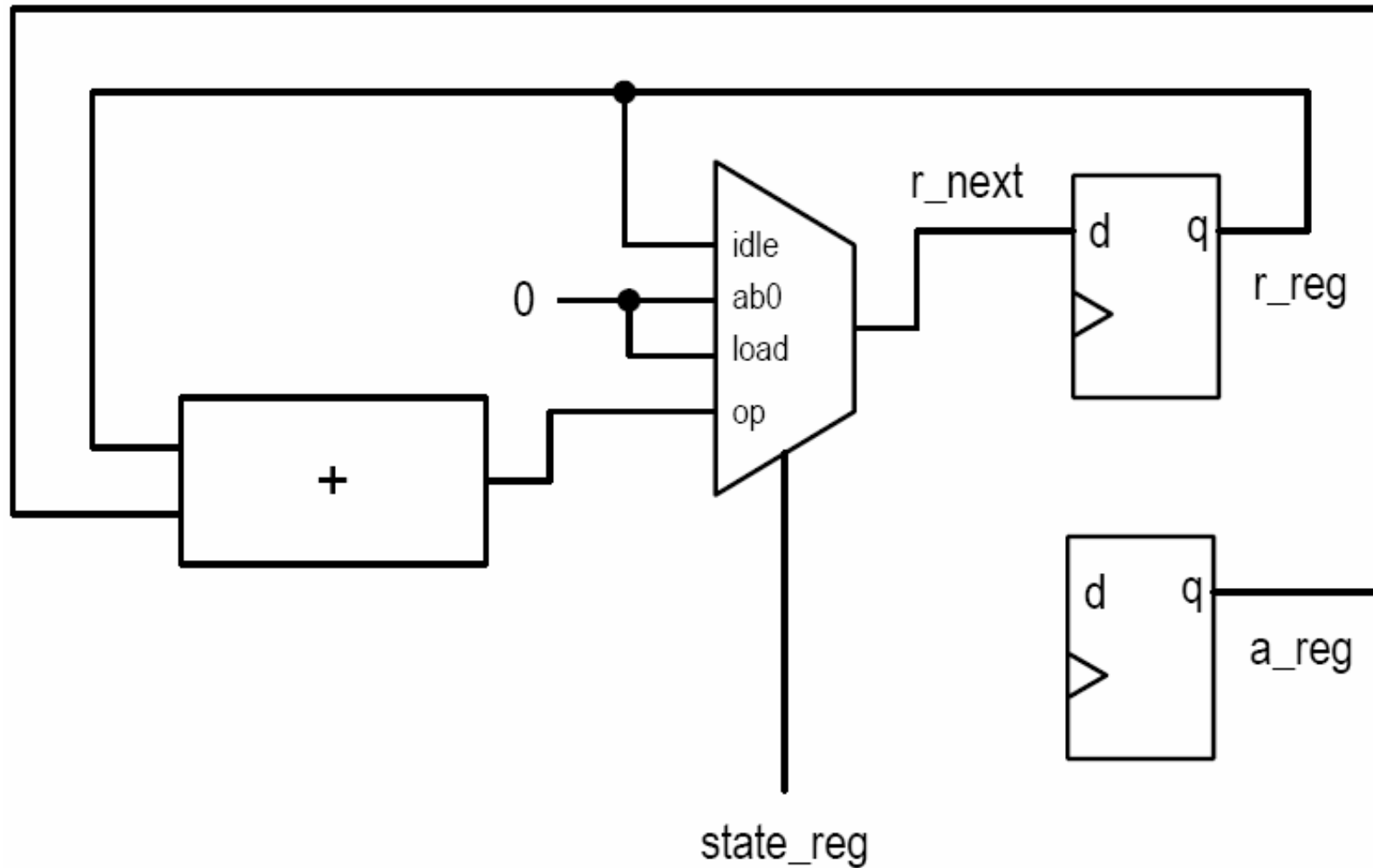

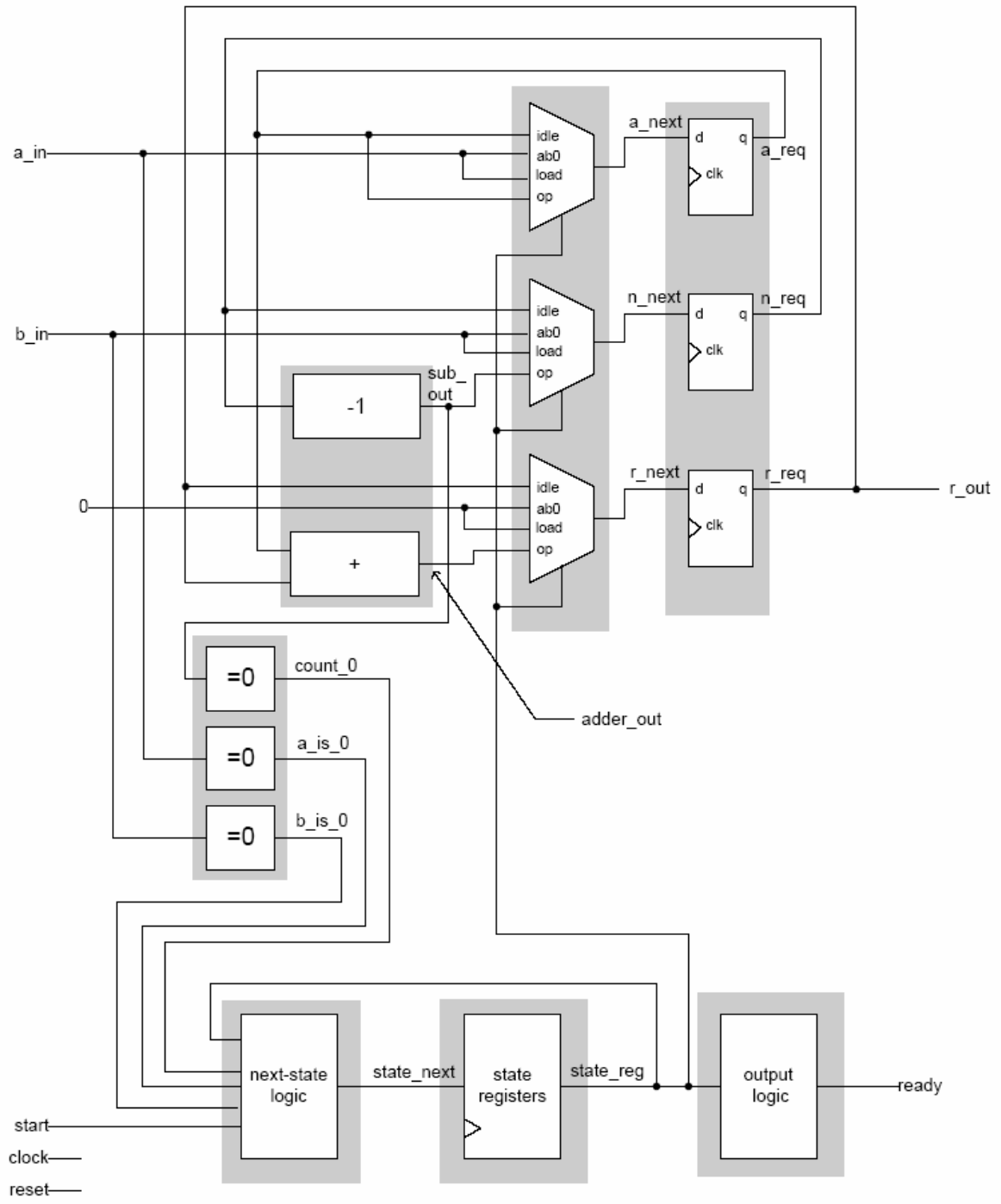

- VHDL code: follow the block diagram

```
library ieee;
use ieee.std_logic_1164.all;
use ieee.numeric_std.all;

entity seq_mult is
  port(
    clk, reset: in std_logic;
    start: in std_logic;
    a_in, b_in: in std_logic_vector(7 downto 0);
    ready: out std_logic;
    r: out std_logic_vector(15 downto 0)
  );
end seq_mult;
```

```
— control path: state register  
process(clk,reset)  
begin  
    if reset='1' then  
        state_reg <= idle;  
    elsif (clk'event and clk='1') then  
        state_reg <= state_next;  
    end if;  
end process;
```

```

-- control path: next-state/output logic
process(state_reg,start,a_is_0,b_is_0,count_0)
begin
  case state_reg is
    when idle =>
      if start='1' then
        if (a_is_0='1' or b_is_0='1') then
          state_next <= ab0;
        else
          state_next <= load;
        end if;
      else
        state_next <= idle;
      end if;
    when ab0 =>
      state_next <= idle;
    when load =>
      state_next <= op;
    when op =>
      if count_0='1' then
        state_next <= idle;
      else
        state_next <= op;
      end if;
  end case;
end process;

```

```

— control path: output logic
ready <= '1' when state_reg=idle else '0';
— data path: data register
process(clk,reset)
begin
    if reset='1' then
        a_reg <= (others=>'0');
        n_reg <= (others=>'0');
        r_reg <= (others=>'0');
    elsif (clk'event and clk='1') then
        a_reg <= a_next;
        n_reg <= n_next;
        r_reg <= r_next;
    end if;
end process;

```

```

-- data path: routing multiplexer
process (state_reg, a_reg, n_reg, r_reg,
        a_in, b_in, adder_out, sub_out)
begin
    case state_reg is
        when idle =>
            a_next <= a_reg;
            n_next <= n_reg;
            r_next <= r_reg;
        when ab0 =>
            a_next <= unsigned(a_in);
            n_next <= unsigned(b_in);
            r_next <= (others => '0');
        when load =>
            a_next <= unsigned(a_in);
            n_next <= unsigned(b_in);
            r_next <= (others => '0');
        when op =>
            a_next <= a_reg;
            n_next <= sub_out;
            r_next <= adder_out;
    end case;
end process;

```

```

-- data path: functional units
adder_out  <= ("00000000" & a_reg) + r_reg;
sub_out    <= n_reg - 1;

-- data path: status
a_is_0    <= '1' when a_in="00000000" else '0';
b_is_0    <= '1' when b_in="00000000" else '0';
count_0   <= '1' when n_next="00000000" else '0';

-- data path: output
r <= std_logic_vector(r_reg);

```

- Use of register in decision box
 - Register is updated when the FSM exits current state
 - How to represent `count_0='1'` using register?

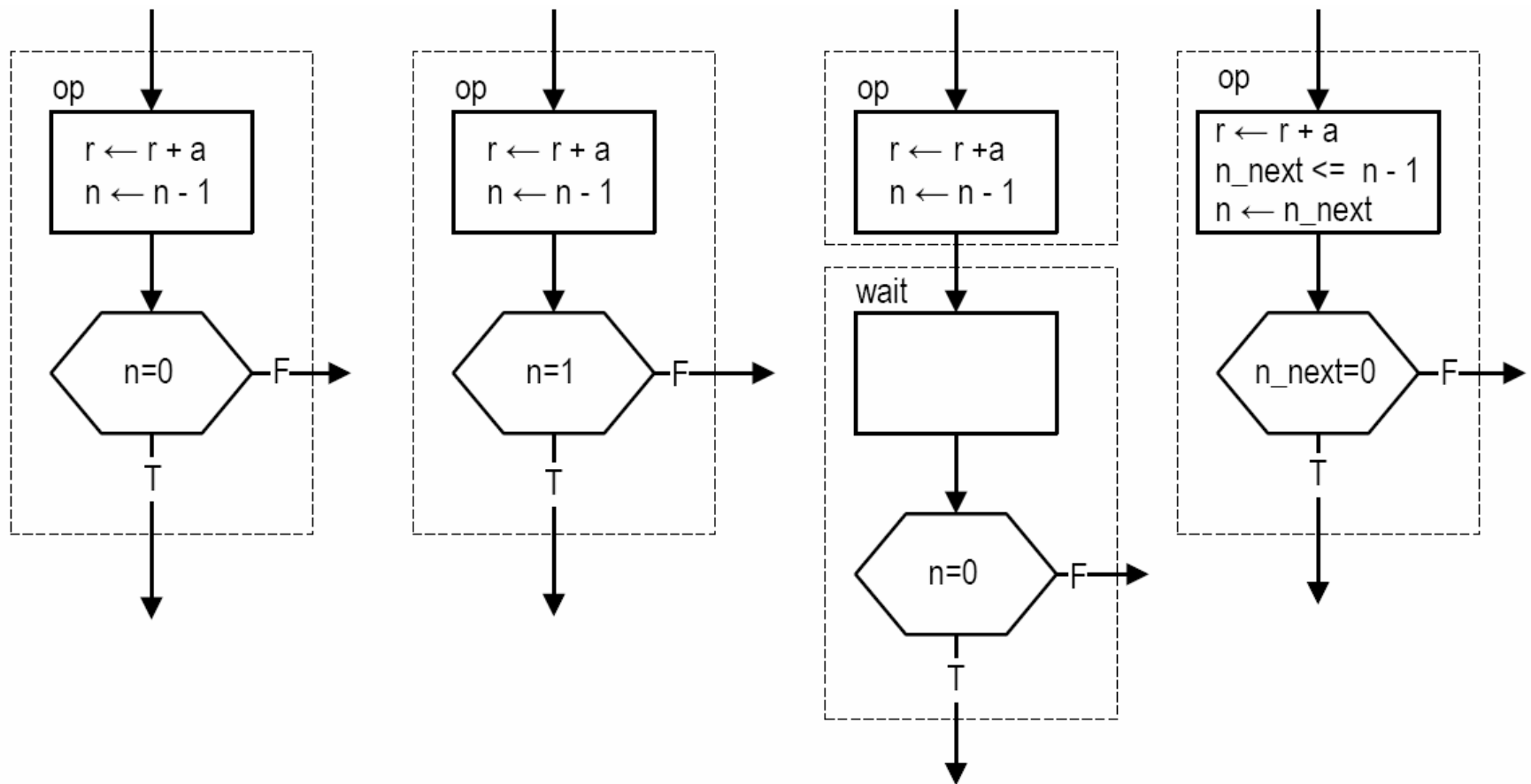

- Other VHDL coding styles:
 - Various code segments can be combined
 - Should always separate registers from combinational logic
 - May be a good idea to isolate the main functional units

- E.g., 2-segment code

```
-- state and data register  
process(clk,reset)  
begin  
    if reset='1' then  
        state_reg <= idle;  
        a_reg <= (others=>'0');  
        n_reg <= (others=>'0');  
        r_reg <= (others=>'0');  
    elsif (clk'event and clk='1') then  
        state_reg <= state_next;  
        a_reg <= a_next;  
        n_reg <= n_next;  
        r_reg <= r_next;  
    end if;  
end process;
```

```

-- combinational circuit
process (start, state_reg, a_reg, n_reg, r_reg,
        a_in, b_in, n_next)
begin
    -- default value
    a_next <= a_reg;
    n_next <= n_reg;
    r_next <= r_reg;
    ready <= '0';
    case state_reg is
        when idle =>
            if start='1' then
                if (a_in="00000000" or b_in="00000000") then
                    state_next <= ab0;
                else
                    state_next <= load;
                end if;
            else
                state_next <= idle;
            end if;
            ready <= '1';

```

```

when ab0 =>
    a_next <= unsigned(a_in);
    n_next <= unsigned(b_in);
    r_next <= (others=>'0');
    state_next <= idle;
when load =>
    a_next <= unsigned(a_in);
    n_next <= unsigned(b_in);
    r_next <= (others=>'0');
    state_next <= op;
    ready <='0';
when op =>
    n_next <= n_reg - 1;
    r_next <= ("00000000" & a_reg) + r_reg;
    if (n_next="00000000") then
        state_next <= idle;
    else
        state_next <= op;
    end if;
    ready <='0';
end case;
end process;
r_out <= std_logic_vector(r_reg);

```

4. Alternative design of a repetitive-addition multiplier

- Resource sharing
 - Hardware can be shared in a time-multiplexing fashion
 - Assign the operation in different states
 - Most complex circuits in the FSMD design is normally the functional units of the datapath
- Sharing in repetitive addition multiplier
 - Addition and decrementing
 - The same adder can be used in 2 states

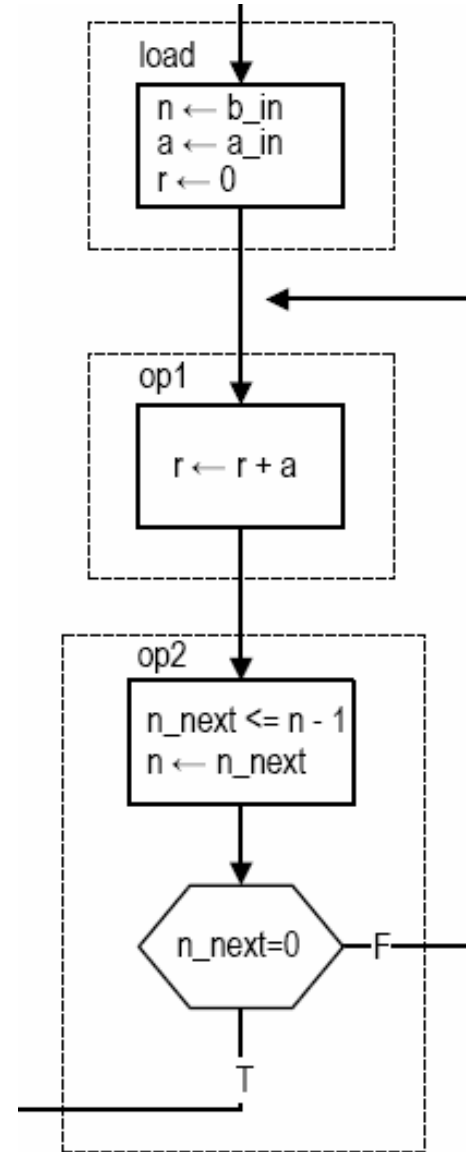
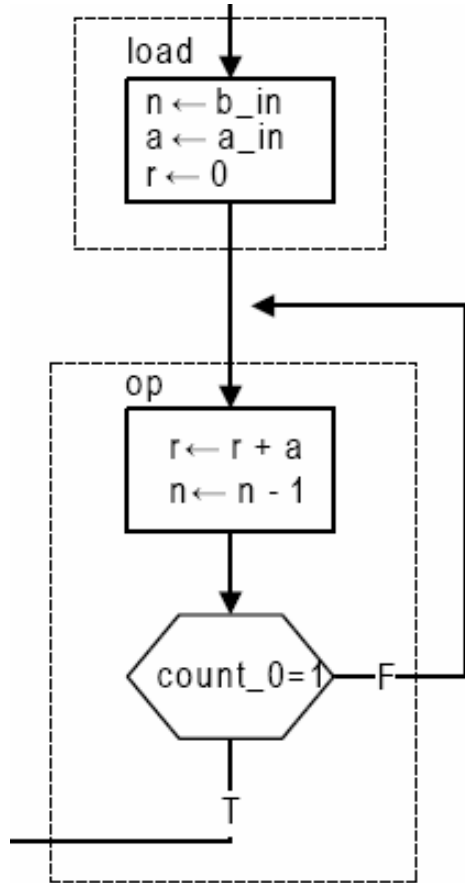

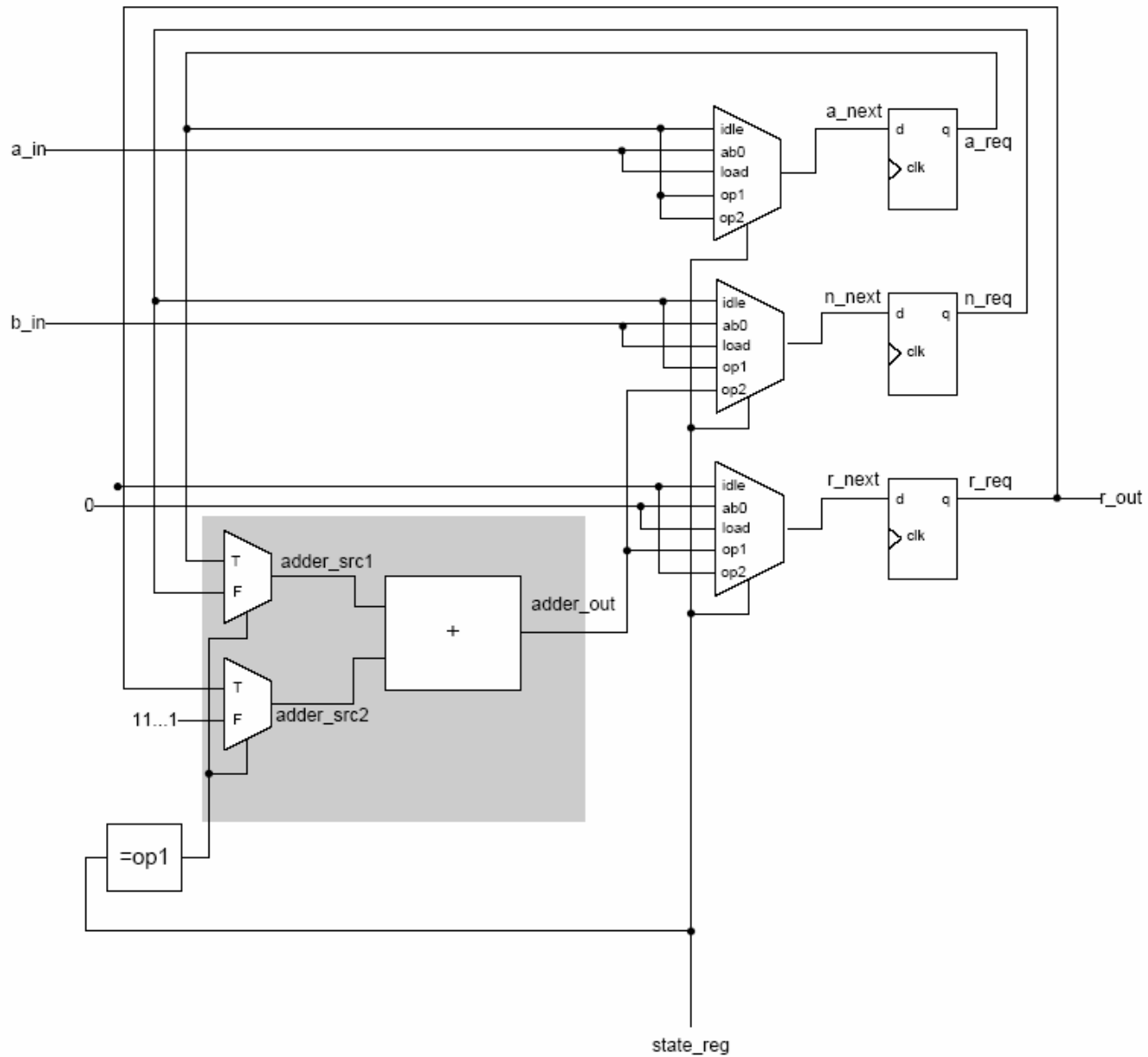

```
when op1 =>
    r_next <= adder_out;
    state_next <= op2;
when op2 =>
    n_next <= adder_out(WIDTH-1 downto 0);
    if (n_next="00000000") then
        state_next <= idle;
    else
        state_next <= op1;
    end if;
```



```

-- data path input routing and functional units
process(state_reg,r_reg, a_reg, n_reg)
begin
    if (state_reg=op1) then
        adder_src1 <= r_reg;
        adder_src2 <= "00000000" & a_reg;
    else -- for op2 state
        adder_src1 <= "00000000" & n_reg;
        adder_src2 <= (others=>'1');
    end if;
end process;
adder_out <= adder_src1 + adder_src2;

```

- Mealy-controlled operation

- Control signals is edge-sensitive

- Mealy output is faster and requires fewer states

- E.g.,

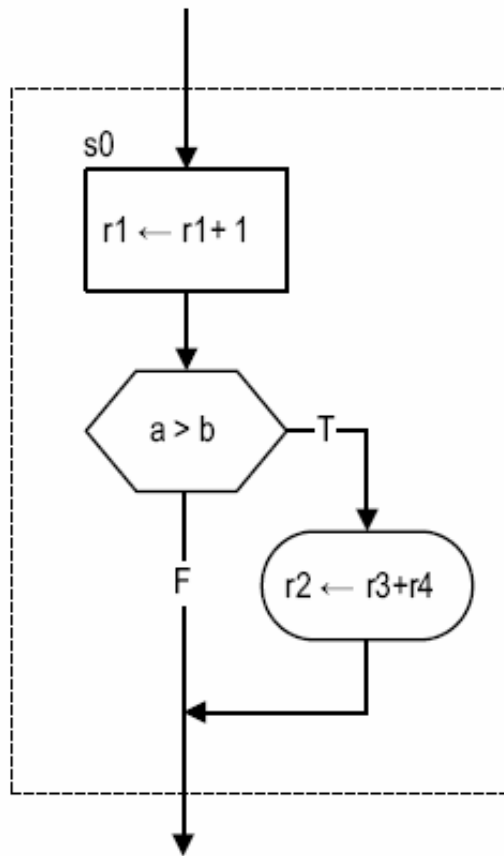

(a) ASMD block

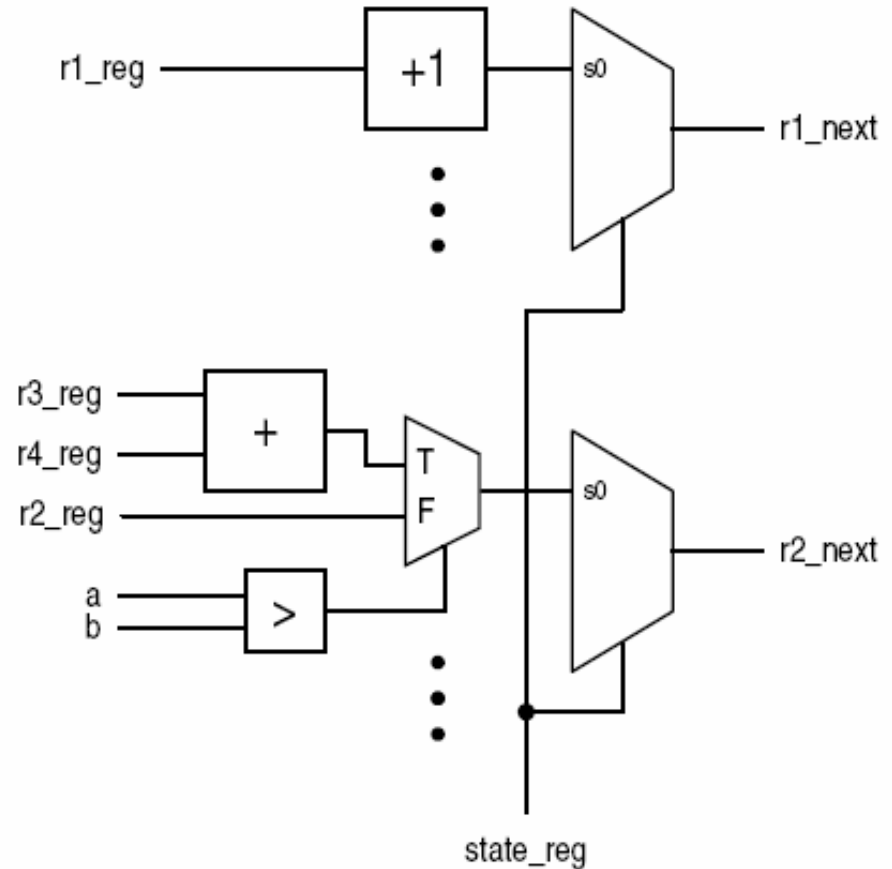

(b) Conceptual block diagram

- Mealy control signal for multiplier
 - load and ab0 states perform no computation
 - Mealy control can be used to eliminate ab0 and load states

- r, n, b register loaded using Mealy signal

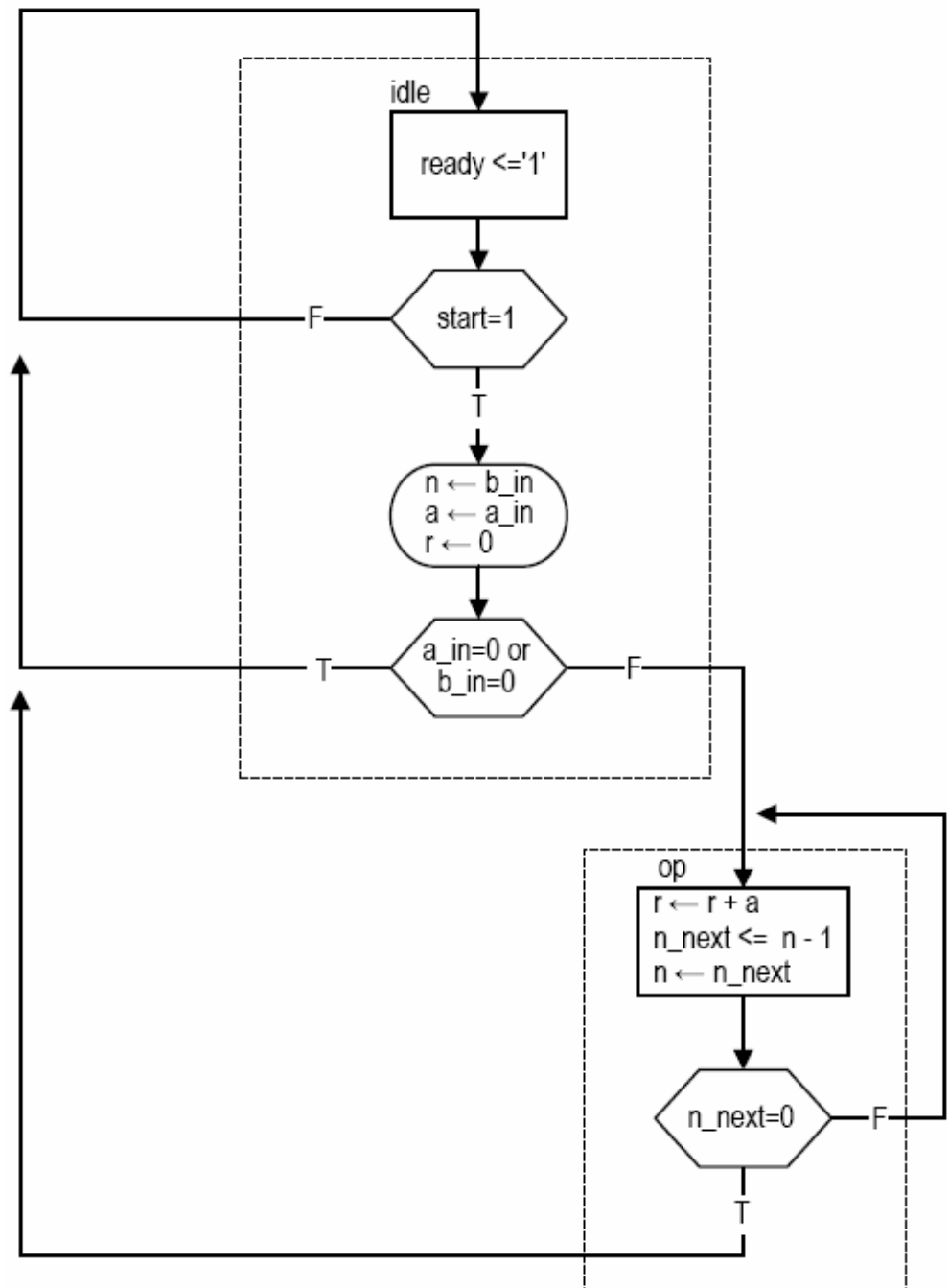

```

case state_reg is
  when idle =>
    if start='1' then
      a_next <= unsigned(a_in);
      n_next <= unsigned(b_in);
      r_next <= (others=>'0');
      if a_in="00000000" or b_in="00000000" then
        state_next <= idle;
      else
        state_next <= op;
      end if;
    else
      state_next <= idle;
    end if;
    ready <='1';
  when op =>
    n_next <= n_reg - 1;
    r_next <= ("00000000" & a_reg) + r_reg;
    if (n_next="00000000") then
      state_next <= idle;
    else
      state_next <= op;
    end if;

```

5. Clock rate and Performance of FSMD

- Maximal clock rate
 - More difficult to analyze because of two interactive loops
 - The boundary of the clock rate can be found

- Best-case scenario:
 - Control signals needed at late stage
 - Status signal available at early stage

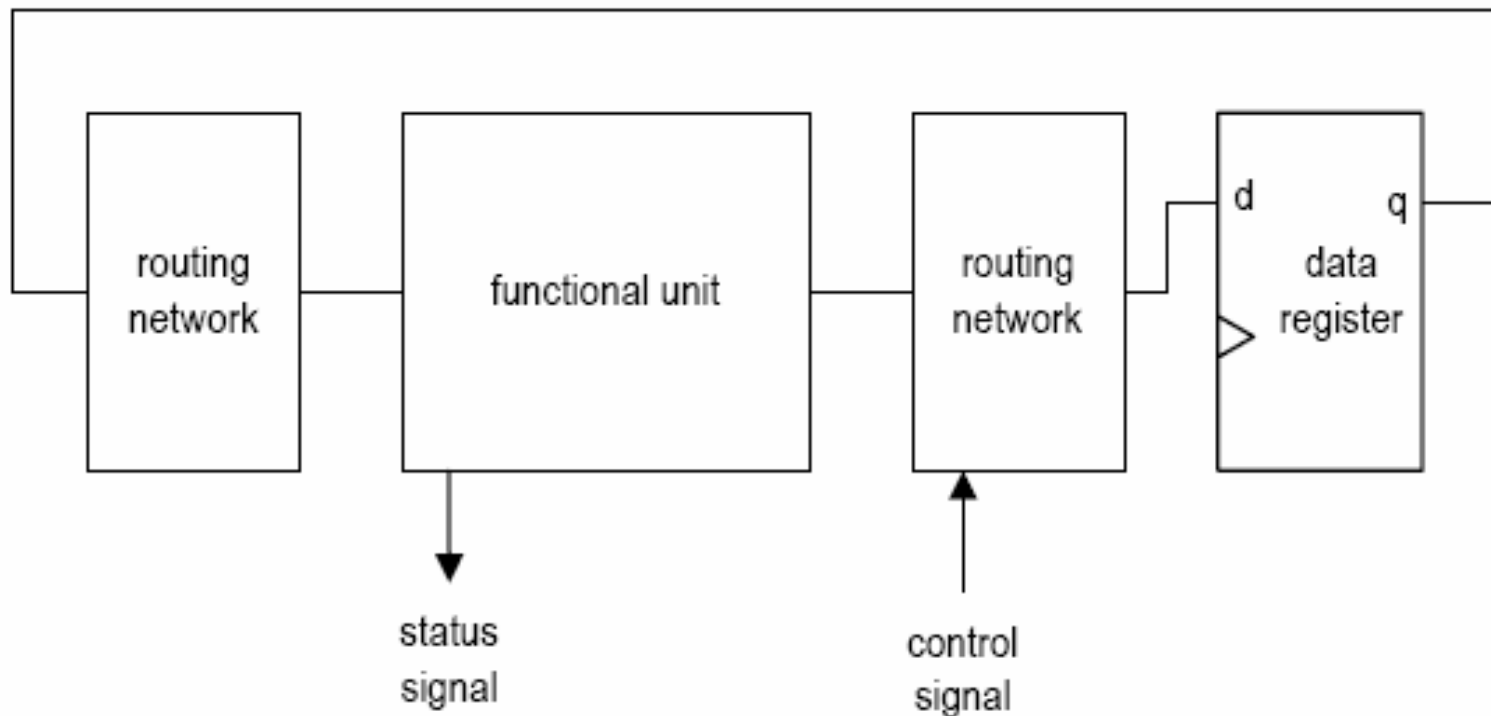

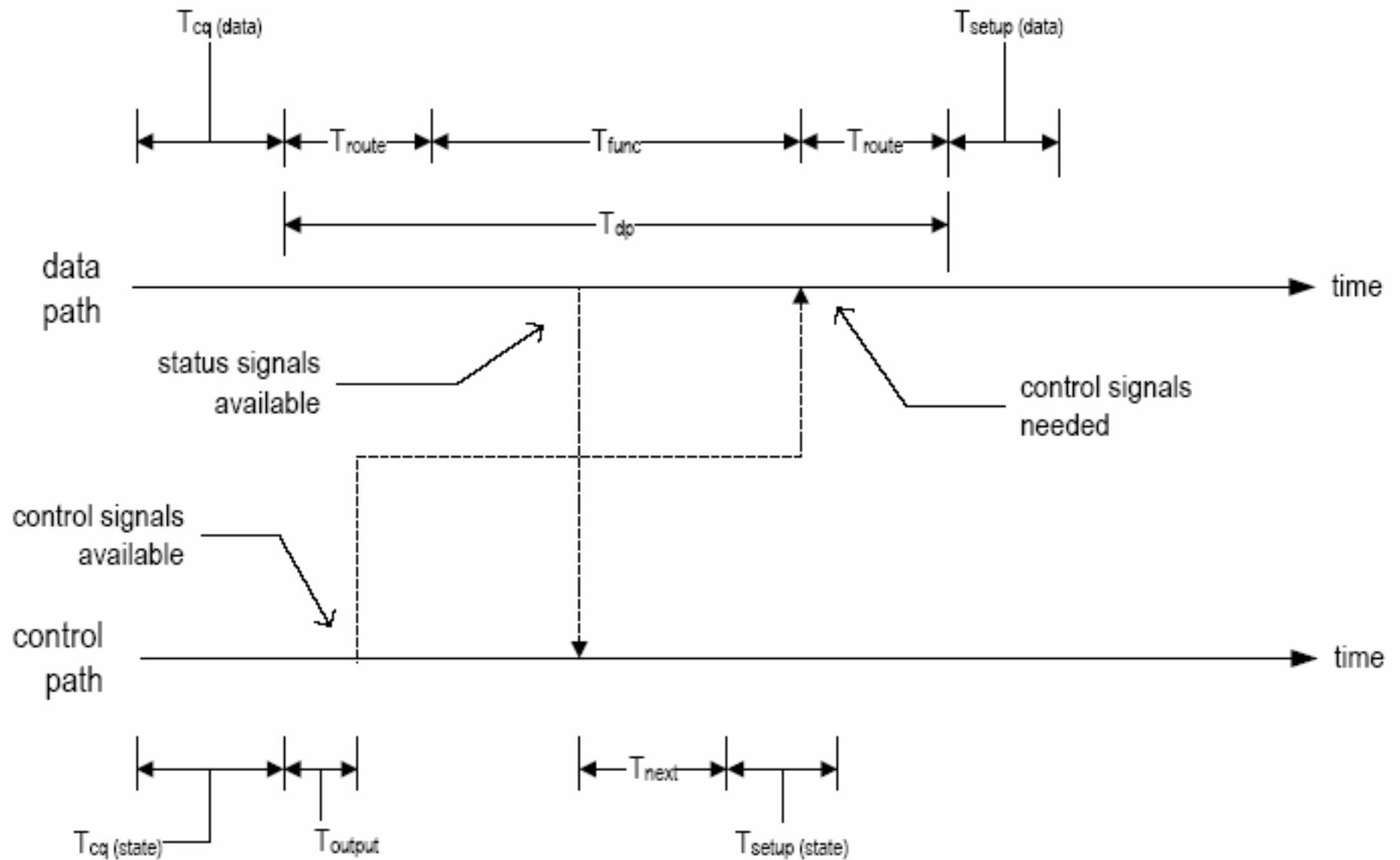

$$T_c = T_{cq}(data) + T_{dp} + T_{setup}(data)$$

- Best-case scenario:
 - Control signals needed at early stage
 - Status signal available at late stage

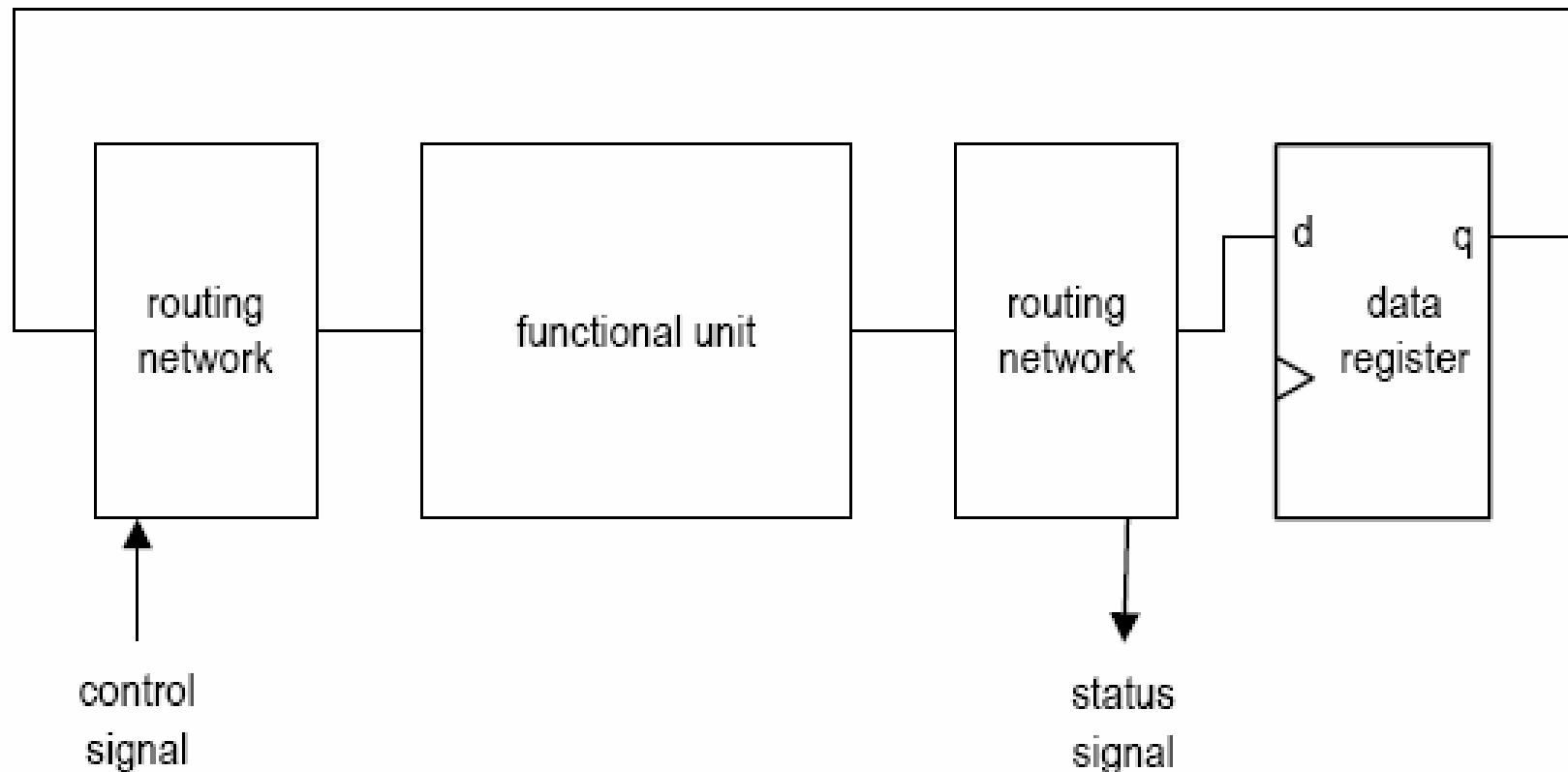

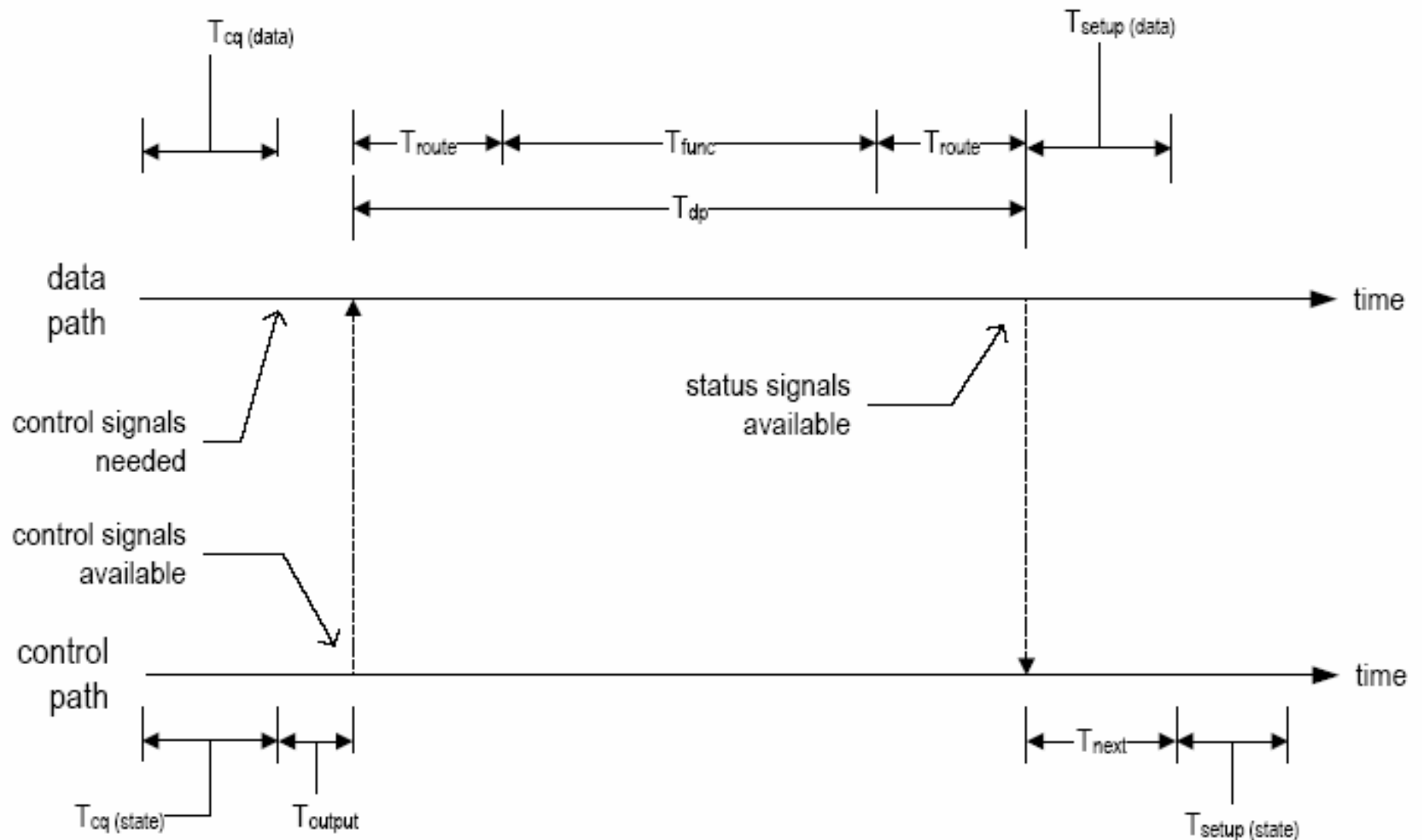

$$T_c = T_{cq(state)} + T_{output} + T_{dp} + T_{next} + T_{setup(state)}$$

$$T_{cq} + T_{dp} + T_{setup} \leq T_c \leq T_{cq} + T_{output} + T_{dp} + T_{next} + T_{setup}$$

$$\frac{1}{T_{cq} + T_{output} + T_{dp} + T_{next} + T_{setup}} \leq f \leq \frac{1}{T_{cq} + T_{dp} + T_{setup}}$$

- Performance of FSMD
 - T_c : Clock period
 - K : # clock cycles to complete the computation
 - Total time = $K * T_c$
- K determined by algorithm, input patterns etc.

- 8-bit input
 - Best: $b=0$, $K=2$
 - Worst: $b=255$, $K=257$
- N-bit input:
 - Worst:

$$K = 2 + (2^n - 1)$$

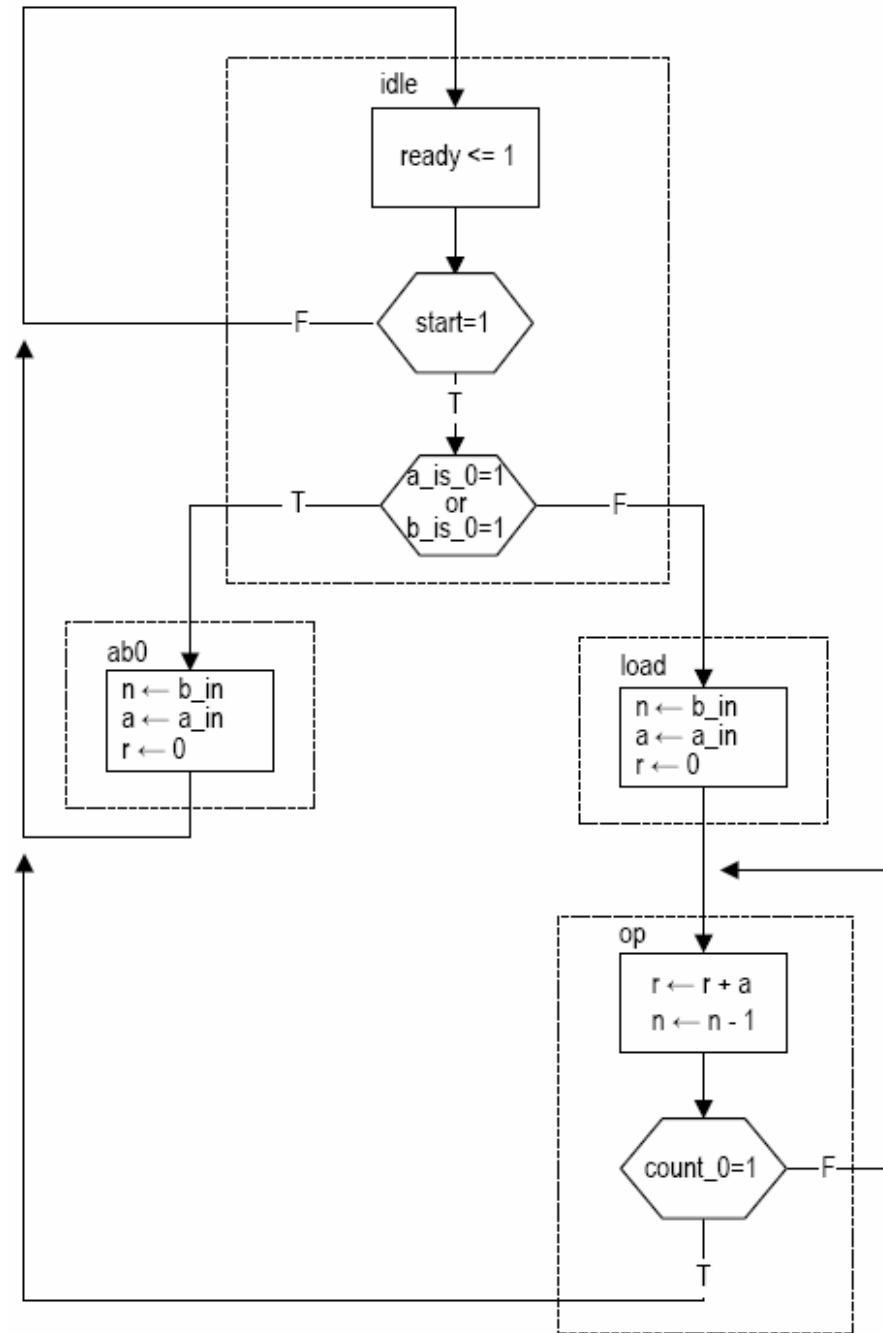

- 8-bit input
 - Best: $b=0, K=2$
 - Worst: $b=255, K=2 + 255*2$
- N-bit input:
 - Worst: $K=2+2*(2^n-1)$

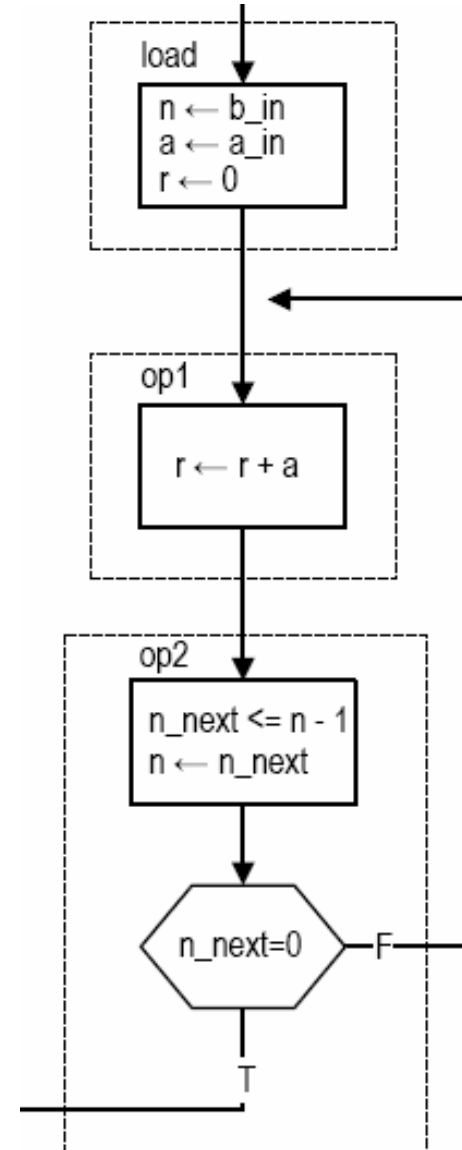

6. Sequential add-and-shift multiplier

\times				a_3	a_2	a_1	a_0	multiplicand
				b_3	b_2	b_1	b_0	multiplier
				a_3b_0	a_2b_0	a_1b_0	a_0b_0	
			a_3b_1	a_2b_1	a_1b_1	a_0b_1		
		a_3b_2	a_2b_2	a_1b_2	a_0b_2			
$+$	a_3b_3	a_2b_3	a_1b_3	a_0b_3				
	y_7	y_6	y_5	y_4	y_3	y_2	y_1	y_0
								product

1. Multiply the digits of the multiplier (b_3, b_2, b_1 and b_0) by the multiplicand (A) one at a time to obtain $b_3 * A, b_2 * A, b_1 * A$ and $b_0 * A$. The $b_i * A$ operation is bitwise and operations of b_i and the digits of A :

$$b_i * A = (a_3 \cdot b_i, a_2 \cdot b_i, a_1 \cdot b_i, a_0 \cdot b_i)$$

2. Shift $b_i * A$ to the left by i positions according to the position of digits b_i .
3. Add the shifted $b_i * A$ to obtain the final product.

```

n = 0;
p = 0;
while (n != 8) {
    if (b_in(n) = 1) then {
        p = p + (a_in << n);
    }
    n = n + 1;
}
return (p);

```



```

a = a_in;
b = b_in;
n = 8;
p = 0;
while (n!=0) {
    if (b(0)=1) then{
        p = p + a;}
    a = a << 1;
    b = b >> 1;
    n = n-1;}
return (p);

```

```

a = a_in;
b = b_in;
n = 8;
p = 0;
op:  if b(0)=1 then {
        p = p + a;}
        a = a << 1;
        b = b >> 1;
n = n-1
if (n !=0) then{
    goto op;}
return (p);

```

- Note the use of b_next and n_next
- $a \ll 1$ and $b \gg 1$ require no logic
- 8-bit input
 - Best: $b=0$,
 $K = 1 + 8$
 - Worst: $b=255$,
 $K = 1 + 8 \cdot 2$
- N-bit input:
 - Worst:
 $K=2+2 \cdot n$

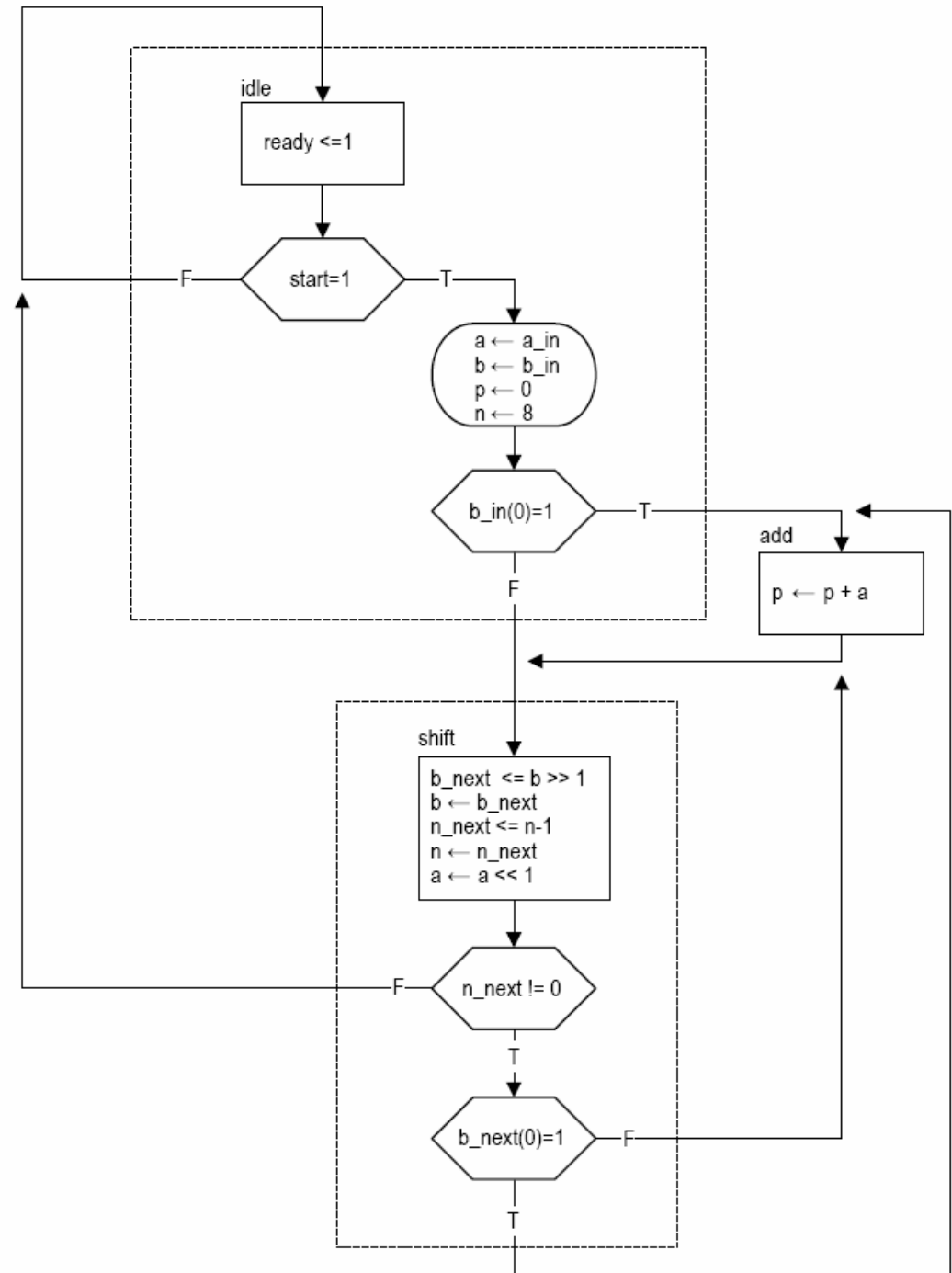

```

architecture shift_add_raw_arch of seq_mult is
    constant WIDTH: integer:=8;
    constant C_WIDTH: integer:=4; -- width of the counter
    constant C_INIT: unsigned(C_WIDTH-1 downto 0):="1000";
    type state_type is (idle, add, shift);
    signal state_reg, state_next: state_type;
    signal b_reg, b_next: unsigned(WIDTH-1 downto 0);
    signal a_reg, a_next: unsigned(2*WIDTH-1 downto 0);
    signal n_reg, n_next: unsigned(C_WIDTH-1 downto 0);
    signal p_reg, p_next: unsigned(2*WIDTH-1 downto 0);

```

```

-- combinational circuit
process(start, state_reg, b_reg, a_reg,
        n_reg, p_reg, b_in, a_in, n_next)
begin
    b_next <= b_reg;
    a_next <= a_reg;
    n_next <= n_reg;
    p_next <= p_reg;
    ready <='0';
    case state_reg is
        when idle =>
            if start='1' then
                b_next <= unsigned(b_in);
                a_next <= "00000000" & unsigned(a_in);
                n_next <= C_INIT;
                p_next <= (others=>'0');
                if b_in(0)='1' then
                    state_next <= add;
                else
                    state_next <= shift;
                end if;
            else
                state_next <= idle;
            end if;
            ready <='1';
        when add =>
            p_next <= p_reg + a_reg;
            state_next <= shift;

```

```

when shift =>
    n_next <= n_reg - 1;
    b_next <= '0' & b_reg (WIDTH-1 downto 1);
    a_next <= a_reg(2*WIDTH-2 downto 0) & '0';
    if (n_next /= "0000") then
        if a_next(0)='1' then
            state_next <= add;
        else
            state_next <= shift;
        end if;
    else
        state_next <= idle;
    end if;
end case;
end process;

```

- Refinement

- No major computation done in the shift state:
the add and shift states can be merged
- Data path can be simplified:
 - Replace $2n$ -bit adder with $(n+1)$ -bit adder
 - Reduce the a register from $2n$ bits to n bits
 - Use the lower part of the p register to store B and eliminate the b register

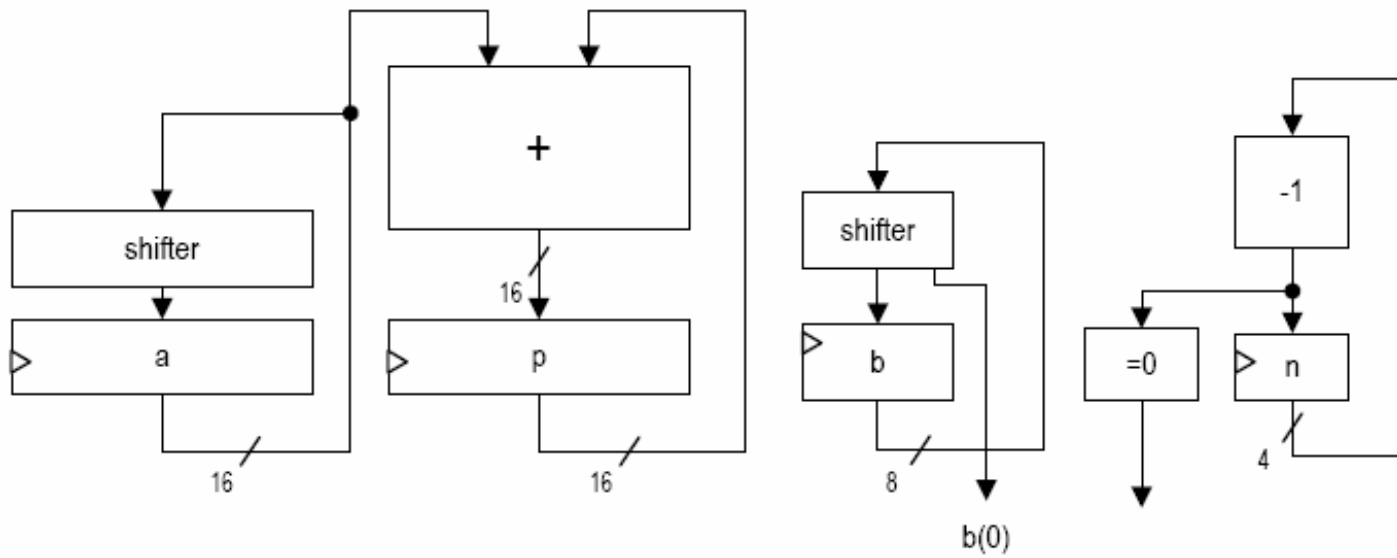

(a) Initial design

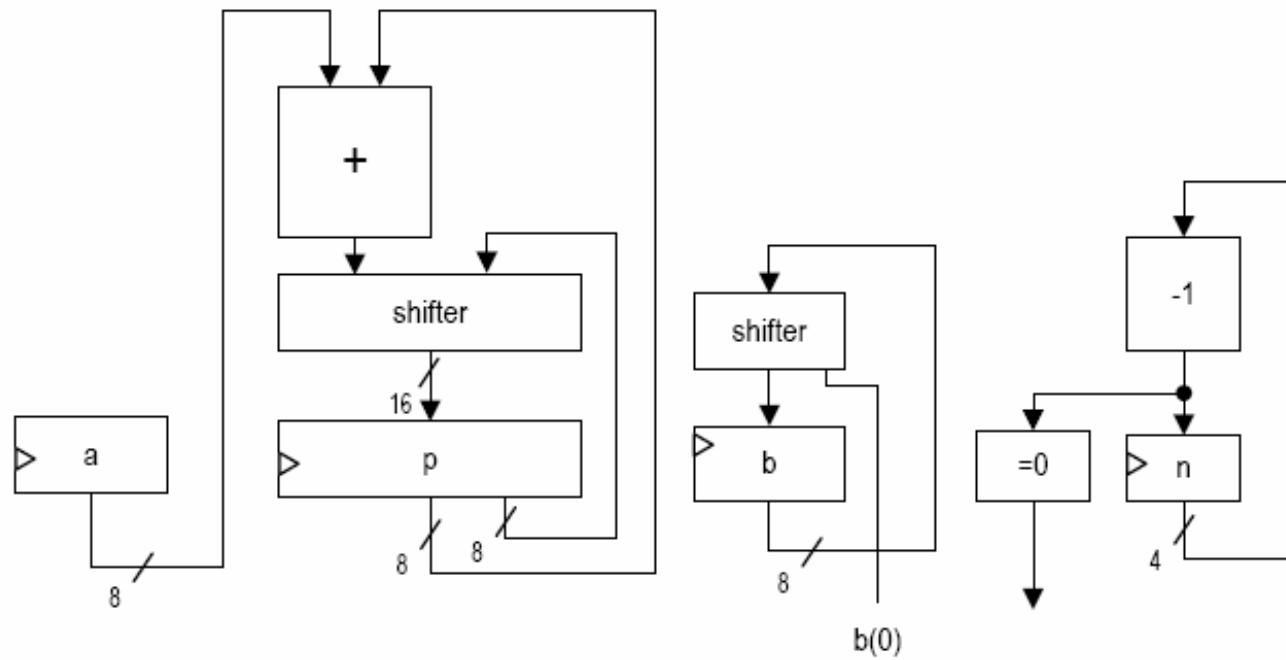

(b) "Shifting p register" design

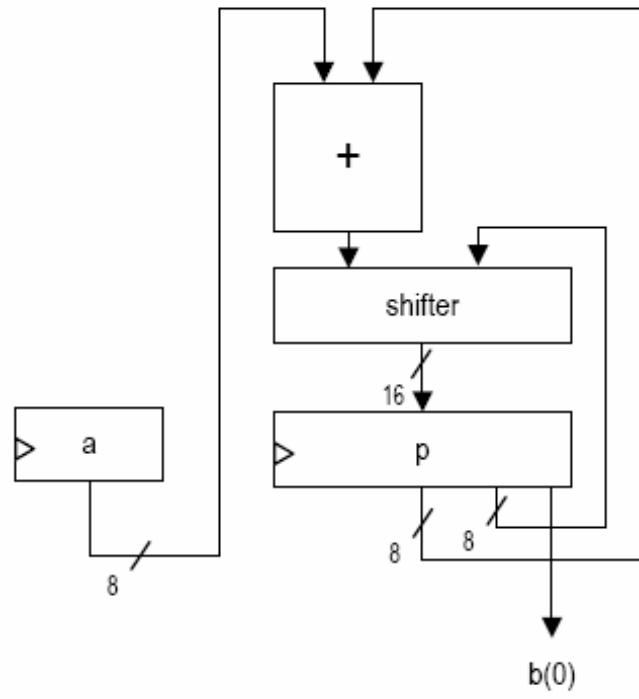

(c) Final design

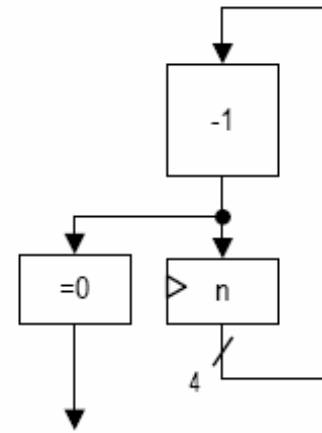

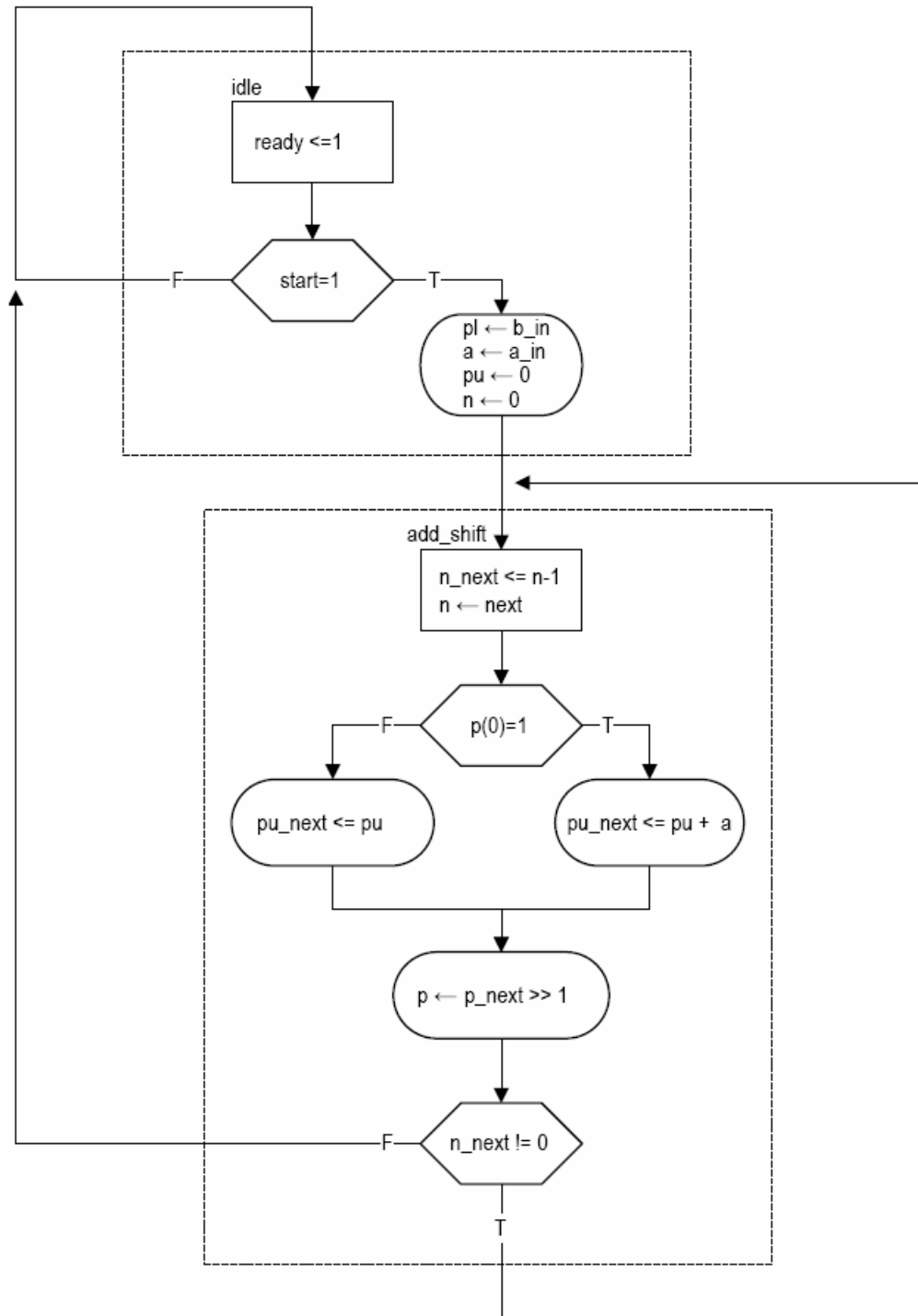

Design method	# Clock cycles	Size of functional units	# Register bits
Repetitive-addition	2 to $2^n + 1$	$2n$ -bit adder, n -bit decrementor	$4n$
Add-and-shift (original)	$n + 1$ to $2n + 1$	$2n$ -bit adder, $\lceil \log_2(n + 1) \rceil$ -bit dec	$5n + \lceil \log_2(n + 1) \rceil$
Add-and-shift (refined)	$n + 1$	n -bit adder, $\lceil \log_2(n + 1) \rceil$ -bit dec	$3n + \lceil \log_2(n + 1) \rceil + 1$